

EMERGENCY LIGHT



Product Features

- Output Power: 3.6W
- Lumens: 200lm
- CCT: 6500K
- Injection-molded thermoplastic ABS housing
- Charging Time: 24Hr
- Discharging Time: 90MIN
- Input Volt: 120/277V
- Battery: 3.6V 1000mAh Ni-CD Battery
- IP Rating: IP20
- LED: 2 *12pcs 2835 ultra bright LED lamps
- Warranty: (5 years warranty for the electrical parts and housing, 3 years warranty for battery)"

EMERGENCY LIGHT

Specifications

Parameter	Description	Value
General Performance	Model	JLEU4
	Mode of operation	Non-Maintained
	Input Voltage	120/277V
	Frequency	60Hz
	Wattage	3.6W
	Output Voltage	5.0VDC
	Output Power	15W Max
	Lumen Output	200Lm
	Colour Temperature	6500K
	Battery	3.6V 1000mAh Ni-Cd Battery
	Max Charge Current (mA)	60mA
	Max Discharge Current (mA)	450mA
	Charging Time	24H
	Discharge Time	90Min
	LED	2 *12pcs 2835 ultra bright LED lamps
	Net Weight	1.1lbs
	IP Rating	IP20
Certification	UL Listed	
Warranty	5 years warranty for the electrical parts and housing, 3 years warranty for battery	

Dimensions

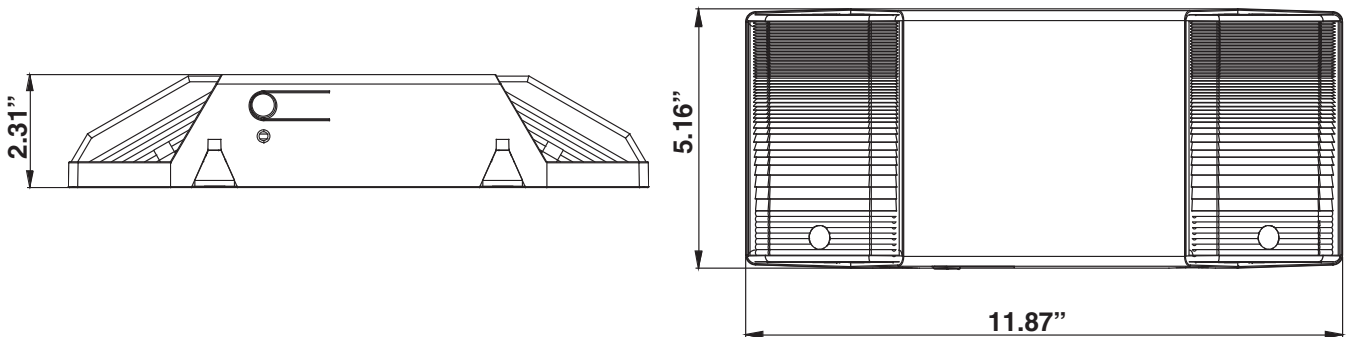

EMERGENCY LIGHT

Installation

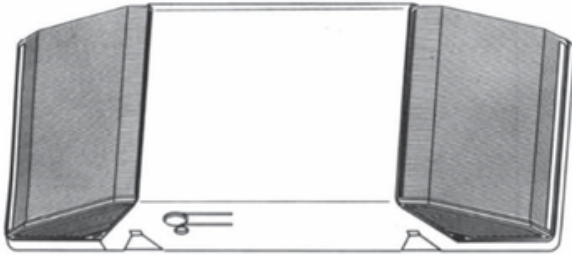

IMPORTANT:

The battery in this unit may not be fully charged. After electricity is connected to the unit, let the battery charge up for at least 24 hours. Then the normal operation of this unit should take effect. To check, press the "TEST" button after the 24 hours of charging time. The light inside the unit should turn on.



IMPORTANT SAFEGUARDS

When using electrical equipment, basic safety precautions should always be followed including the following:

READ AND FOLLOW ALL SAFETY INSTRUCTIONS

- Do not use outdoors.
- Equipment should be mounted in locations and at heights where it will not readily be subject to tampering by unauthorized personnel.
- Do not mount near gas or electric heaters.
- The use of accessory equipment not recommended by the manufacturer may cause an unsafe condition.
- Do not use this equipment for other than its intended use.
- Servicing of this equipment should be performed by qualified service personnel.
- Disconnect AC power before servicing.
- Use caution when servicing batteries. Battery acid can cause burns to skin and eyes. If acid is spilled on skin or eyes, flush acid with fresh water and contact a physician immediately.

SAVE THESE INSTRUCTIONS INSTALLATION INSTRUCTIONS

1. Turn off AC power.
2. Extend unswitched AC line to unit location.
3. Remove both lenses by pulling away from housing. Do not lift unit by lenses. (Diagram A)

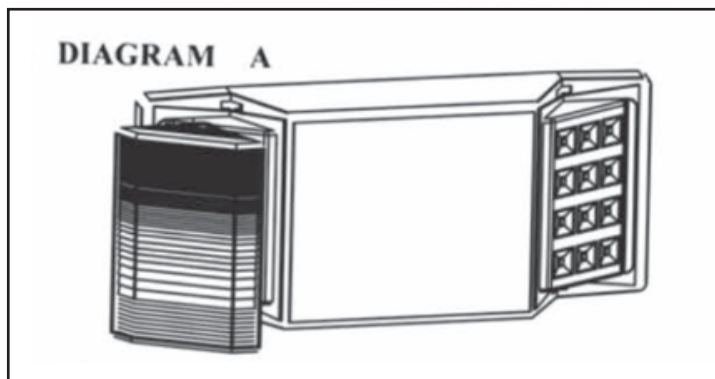

EMERGENCY LIGHT

Installation

LED EMERGENCY LIGHT

4. Remove unit back plate by releasing two tabs at the bottom with a narrow screwdriver blade, and pull away. (Diagram B)
5. For WALL OR CEILING MOUNTING, place screws through appropriate keyhole slots and tighten. Be sure to orient the back plate, so the test switch faces the bottom, or desired direction, if ceiling mounted. FOR MOUNTING TO A JUNCTION BOX, Complete wiring connections as per step 6, and secure to box by removing appropriate knockouts in back plate. FOR CONDUIT ENTRY, secure Back plate to wall or ceiling with suitable anchors. Knock out the conduit entry hole in the top of the unit housing, and install conduit with bushing.
6. Attach unswitched AC circuit wires to unit AC input wire with wire nuts. INSULATE UNUSED LEAD. For 120 VAC input, follow Diagram C. For 277 VAC input, follow Diagram D.
7. When ready to energize AC circuit, connect red battery lead to battery positive terminal. Verify battery negative terminal is connected to battery blue wire.
8. AC must be off when mating unit housing to back plate. Align AC connector over circuit board and press onto back plate until the retaining tabs snap through the housing. Reinstall both lenses by slight squeezing of the top and bottom mounting tabs.

TESTING:

To test, depress test switch. The emergency lamps will illuminate. When switch is released, LED will go off. Allow unit to charge for 48 hours before full load testing. IMPORTANT

NOTICE:

This equipment is furnished with a low voltage disconnect circuit to prevent damage by over discharging the battery. However, if the AC supply to the unit is to be disconnected for prolonged periods of time the battery

MUST BE DISCONNECTED.

If unit fails to perform as described, disconnect AC and battery immediately, and contact either the factory or trained service personnel for assistance.

TECHNICAL PARAMETERS:

1. BATTERY: 3.6V1000mAhNi-Cd
2. LED: 2X12PCS SMDLED
3. DURATION TIME: 90 MINUTES

Warning:

Unused wires must be capped using enclosed wire nuts.

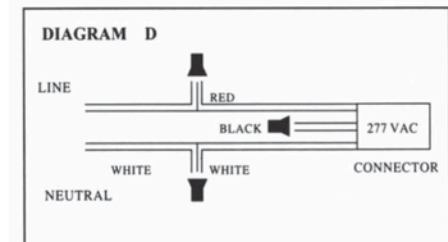
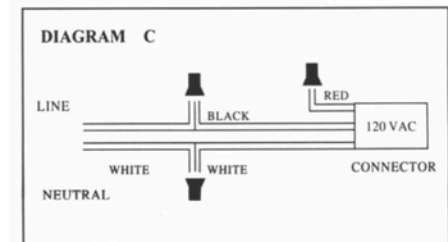
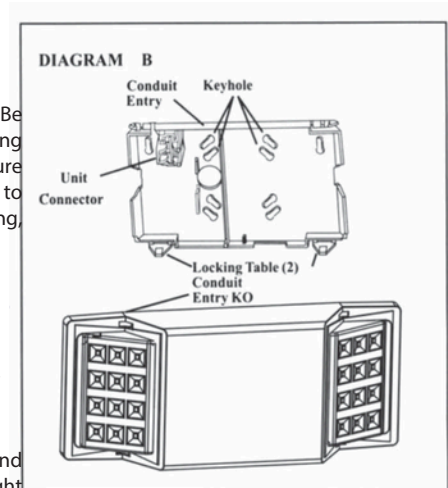

EMERGENCY LIGHT

Application Picture



PACKAGE

Carton (Inch)	Qty / Carton 6 Per Box	Net Weight / Carton	Gross Weight / Carton
12.52x71x7.08		6.61lbs	10.32lbs