

# CAPSULES LED MODULES

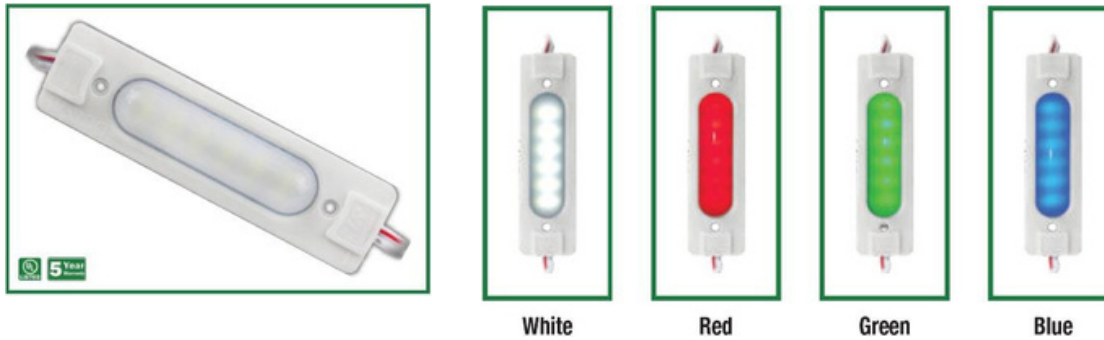

Beyond LED's capsules are high quality LED modules specially designed for outdoor applications including construction activity, retrofit of medium size and large size channel letters, or utility of sign decoration. The product is available in White, Green, Red, and Blue colors. HD modules are easily customized to meet all required specification. The excellent heat dissipation provided by the integrated heat sink reduces the degradation of light and color deviation. The double-sided VHB 3M tape, at the back of the product, allows easy mounting and installation ensuring reliability. In addition, the ultrasonically welded body of these modules and its IP65 rating guarantees water resistance for signage applications.

## Product Features

Operating temperature: -25°C to 60°C

High Lumens per Watt efficacy

Constant voltage LED driver integrated which eliminates the need for an external driver or ballast

Complies with UL safety regulations

This product is IP65 rated, therefore, it is suited for both indoor and outdoor applications

Constant current 12V DC driving system

Aluminium PCB board

3 years warranty

1.8 Watt per module, specially designed for thicker large channel letters

No UV or IR in the beam

Environment friendly with no mercury

Easy to install and operate, with instant and no humming

Energy saving with long lifespan

Watts	Lumens	CCT	Certification
1.8W	252LM/Module	6500K	UL
1.8W	N/A	N/A	UL
1.8W	N/A	N/A	UL
1.8W	N/A	N/A	UL

## Specifications

Parameter	Description	Value
General Performance	Model #	GLMD145-W
	Product	LED Module High Efficiency 6500K/1.8W White 12V Pack of 50
	Wattage	1.8W
	Lumen	Up to 252LM/Module
	Lumen Efficacy	Up to 161LM/W
	Color Temperature	6500K
Electrical	Input Voltage	12V
	Rated Current per Module	180mA
	Power consumption per Module	2.1W
	Chain can be subdivided	Every 1 Module
Physical	Operating Temperature	-25°C TO 60°C
	Storage Temperature	-30°C TO 70°C
	Consecutive Modules connected	Max. 40
	Modules per bag	50
	LED Brand	San'an
	LED Type	SMD5730
	LED per Module	9
	Housing	Aluminium PCB board
	Housing Color	White
	IP Rating	WET (IP65)
Qualification	Life Span	50,000 h
	Warranty	3 years warranty with 24/7 operating hours Luminaire lifetime at 25°C

## Specifications

Parameter	Description	Value
General Performance	Model #	GLMD145-R
	Product	LED Module High Efficiency 6500K/1.8W Red 12V Pack of 50
	Wattage	1.8W
	Lumen	N/A
	Lumen Efficacy	N/A
	Color Temperature	N/A
Electrical	Input Voltage	12V
	Rated Current per Module	180mA
	Power consumption per Module	2.1W
	Chain can be subdivided	Every 1 Module
Physical	Operating Temperature	-25°C TO 60°C
	Storage Temperature	-30°C TO 70°C
	Consecutive Modules connected	Max. 40
	Modules per bag	50
	LED Brand	San'an
	LED Type	SMD5730
	LED per Module	9
	Housing	Aluminium PCB board
	Housing Color	Red
	Qualification	IP Rating
Life Span		50,000 h
Warranty		3 years warranty with 24/7 operating hours Luminaire lifetime at 25°C

# Specifications

Parameter	Description	Value
General Performance	Model #	GLMD145-B
	Product	LED Module High Efficiency 6500K/1.8W Blue 12V Pack of 50
	Wattage	2.1W
	Lumen	N/A
	Lumen Efficacy	N/A
	Color Temperature	N/A
Electrical	Input Voltage	12V
	Rated Current per Module	178mA
	Power consumption per Module	2.1W
	Chain can be subdivided	Every 1 Module
Physical	Operating Temperature	-25°C TO 60°C
	Storage Temperature	-30°C TO 70°C
	Consecutive Modules connected	Max. 40
	Modules per bag	50
	LED Brand	San'an
	LED Type	SMD5730
	LED per Module	9
	Housing	Aluminium PCB board
	Housing Color	Blue
	Qualification	IP Rating
Life Span		50,000 h
Warranty		3 years warranty with 24/7 operating hours Luminaire lifetime at 25°C

## Specifications

Parameter	Description	Value
General Performance	Model #	GLMD145-G
	Product	LEDModule High Efficiency 6500K/1.8W Green 12VPack of 50
	Wattage	1.8W
	Lumen	N/A
	Lumen Efficacy	N/A
	Color Temperature	N/A
Electrical	Input Voltage	12V
	Rated Current per Module	203mA
	Power consumption per Module	2.4W
	Chain can be subdivided	Every 1 Module
Physical	Operating Temperature	-25°C TO 60°C
	Storage Temperature	-30°C TO 70°C
	Consecutive Modules connected	Max. 40
	Modules per bag	50
	LED Brand	San'an
	LED Type	SMD5730
	LED per Module	9
	Housing	Aluminium PCB board
	Housing Color	Green
Qualification	IP Rating	WET (IP65)
	Life Span	50,000 h
	Warranty	3 years warranty with 24/7 operating hours Luminaire lifetime at 25°C

# Correlated Color Temperature (CCT)

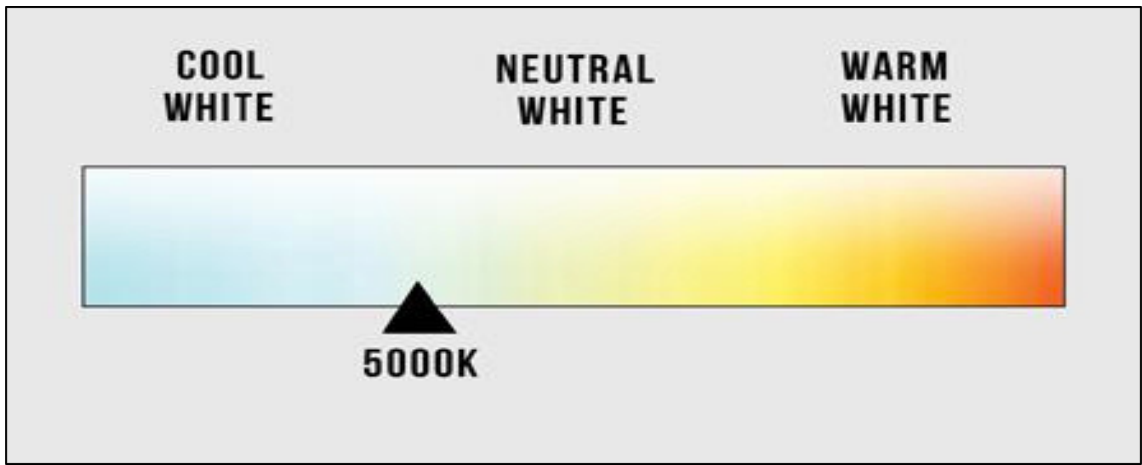

# Dimensions

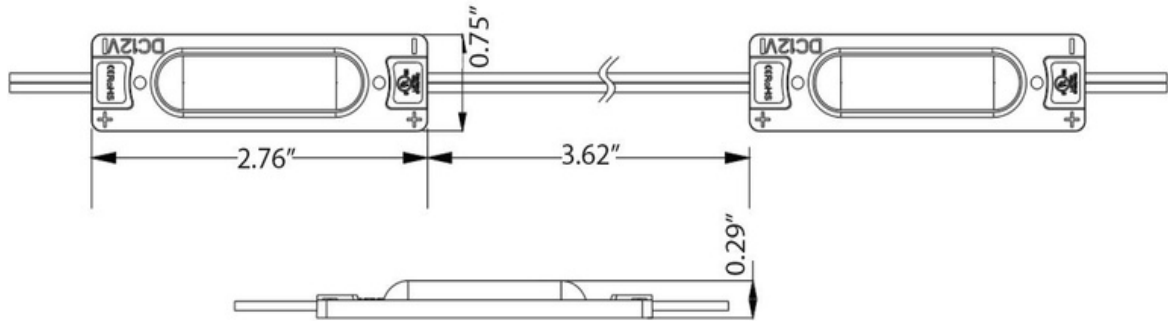

## Spectrum Test Report

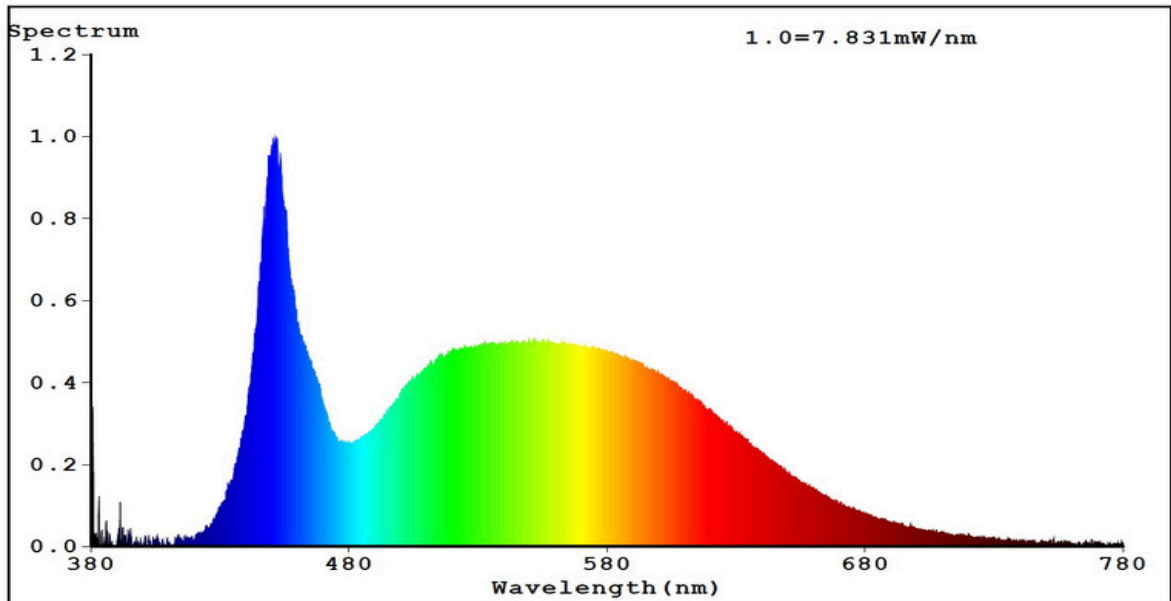

## Caution

1. Can not use the electric generator to test the LED light .
2. Please abide by related country, regional and local law and regulations when installing this fixture.
3. Please turn off the power before installation or maintenance.
4. Proper grounding is required to ensure safety.

## Notice

1. To avoid possibility of electrical shock or fire, the installation personnel must have professional electric knowledge.
2. Please wear gloves to avoid injury before installation.
3. If there is any smoke or spark, please turn off the power immediately and consult a qualified electrician.
4. Please use listed water proof strain relief bushing when connection the supply cord to the outlet box.

## Packaging Info

Bracket Type	Carton Size	Qty/Box	G.W./Box
Outer Box	14.96 X 14.57 X 11.02 in	20 PCS	24.2 lbs

Tolerance of Carton Size:  $\pm 15$  MM, Tolerance of Weight:  $\pm 10\%$ .

## Application & Safety Precautions

To reduce the risk of death, personal injury or property damage from fire, electric shock, falling parts, cuts/abrasions, and other hazards read all warnings and instructions included with and on the fixture box and all fixture labels. Before installing, servicing, or performing routine maintenance upon this equipment, follow these general precautions. Commercial installation, service and maintenance of luminaires should be performed by a qualified licensed electrician.

For the installation: If you are unsure about the installation or maintenance of the luminaires, consult a qualified licensed electrician and check your local electrical code. To prevent wiring damage or abrasion, do not expose wiring to edges of sheet metal or other sharp objects. Do not make or alter any open holes in an enclosure of wiring or electrical components during kit installation.

### WARNING: RISK OF FIRE OR ELECTRICAL SHOCK

Turn off electrical power at fuse or circuit breaker box before wiring fixture to the power supply. Turn off the power when you perform any maintenance. Verify that supply voltage is correct by comparing it with the luminaire label information. Make all electrical and grounded connections in accordance with the National Electrical Code and any applicable local code requirements. All wiring connections should be capped with UL approved wire connectors.

### CAUTION: RISK OF INJURY

Avoid direct eye exposure to the light source while it is on.  
Account for small parts and destroy packing material, as these may be hazardous to children.

## Warranty

### 3 Years Warranty

This product is warranty to be free from defects in workmanship and materials for up to 3 Years from date of purchase. If it fails to do so, please contact Beyond LED technology at [sales@beyondledtechnology.com](mailto:sales@beyondledtechnology.com) or call 1(866) 786-1117 for instructions on replacement.